

Si PIN photodiode



S5971

S5972

S5973 series

High-speed photodiodes (S5973 series: 1 GHz)

S5971, S5972 and S5973 series are high-speed Si PIN photodiodes designed for visible to near infrared light detection. These photodiodes provide wideband characteristics at a low bias, making them suitable for optical communications and other high-speed photometry. S5973 series includes a mini-lens type (S5973-01) that can be efficiently coupled to an optical fiber and a violet sensitivity enhanced type (S5973-02) ideal for violet laser detection.

Features

- **High-speed response**
S5971 : 100 MHz ($V_R=10$ V)
S5972 : 500 MHz ($V_R=10$ V)
S5973 series: 1 GHz ($V_R=3.3$ V)
- **Low price**
- **High sensitivity**
S5973-02: 0.3 A/W, QE=91 % ($\lambda=410$ nm)
- **High reliability**

Applications

- **Optical fiber communications**
- **High-speed photometry**
- **Violet laser detection (S5973-02)**

General ratings / Absolute maximum ratings

Type No.	Dimensional outline/ Window material *1	Package (mm)	Active area size (mm)	Effective active area (mm ²)	Absolute maximum ratings			
					Reverse voltage V_R Max. (V)	Power dissipation P (mW)	Operating temperature T_{opr} (°C)	Storage temperature T_{stg} (°C)
S5971	①/K	TO-18	$\phi 1.2$	1.1	20	50	-40 to +100	-55 to +125
S5972			$\phi 0.8$	0.5				
S5973			$\phi 0.4$	0.12				
S5973-01	②/L							
S5973-02	③/K							

Electrical and optical characteristics

Type No.	Spectral response range λ (nm)	Peak sensitivity wavelength λ_p (nm)	Photo sensitivity S (A/W)				Short circuit current I_{sc} 100 lx (μ A)	Dark current I_D		Temp. coefficient of I_D T_{CID} (times/°C)	Cut-off frequency f_c (GHz)	Terminal capacitance C_t f=1 MHz (pF)	NEP $V_R=10$ V $\lambda=\lambda_p$ (W/Hz ^{1/2})
			λ_p	660 nm	780 nm	830 nm		Typ. (nA)	Max. (nA)				
S5971	320 to 1060	900	0.64	0.44	0.55	0.6	1.0	0.07 *3	1 *3	1.15	0.1 *3	3 *3	7.4 × 10 ⁻¹⁵
S5972		800	0.57			0.55	0.42	0.01 *3	0.5 *3		0.5 *3		3.1 × 10 ⁻¹⁵
S5973		760	0.52	0.51	0.47	0.09	0.001 *4	0.1 *4	1 *4	1.6 *4	1.1 × 10 ⁻¹⁵ *4		
S5973-01						0.42							
S5973-02				0.45	0.3 *2	0.42	0.37	0.07				1.9 × 10 ⁻¹⁵ *2, *4	

*1: Window material K: borosilicate glass, L: lens type borosilicate glass

*2: $\lambda=410$ nm

*3: $V_R=10$ V

*4: $V_R=3.3$ V

Spectral response

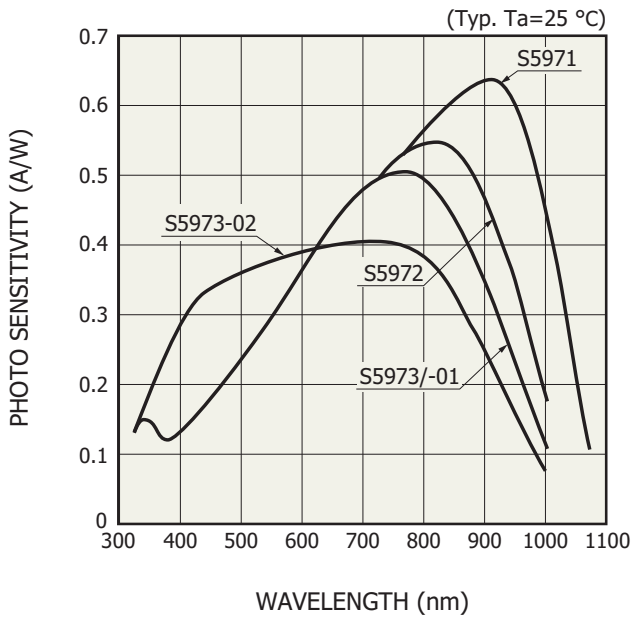

KPINB0157EB

Photo sensitivity temperature characteristics

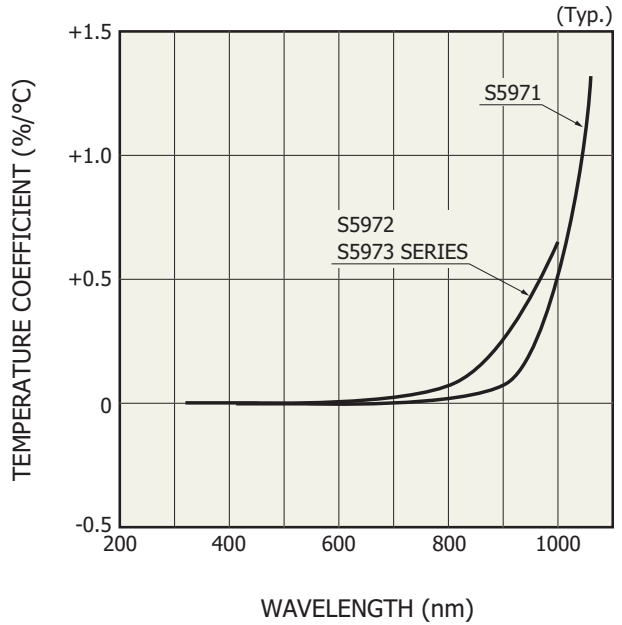

KPINB0158EA

Frequency response

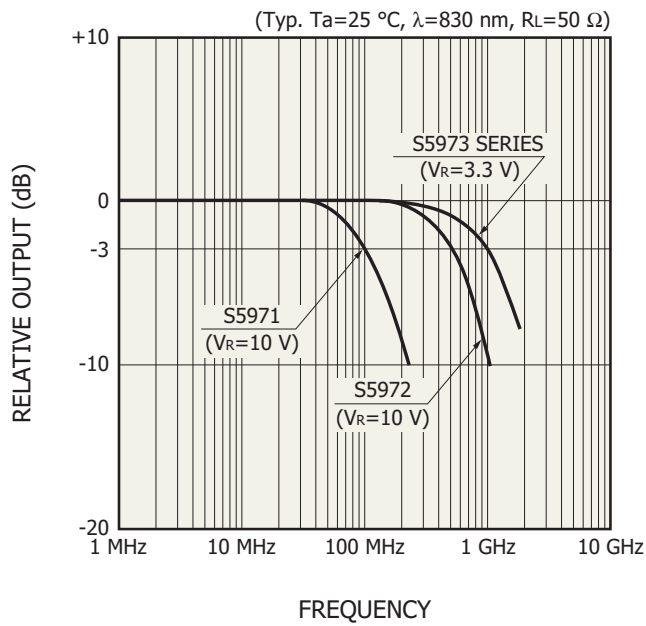

KPINB0159EB

Cut-off frequency vs. reverse voltage

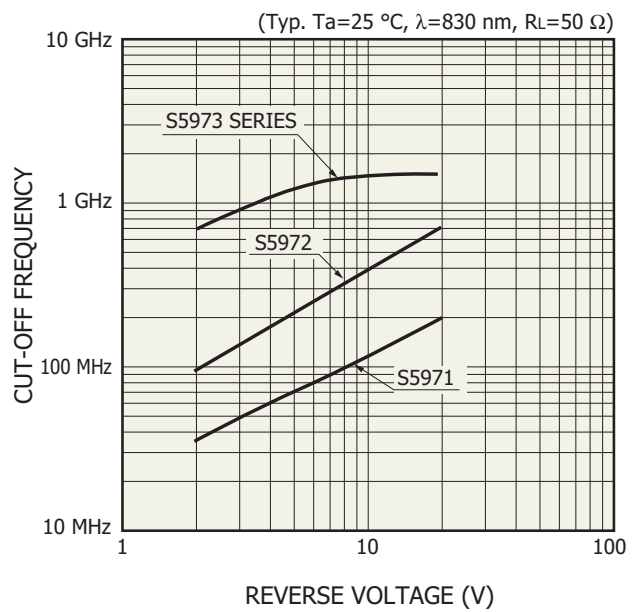

KPINB0160EB

Dark current vs. reverse voltage

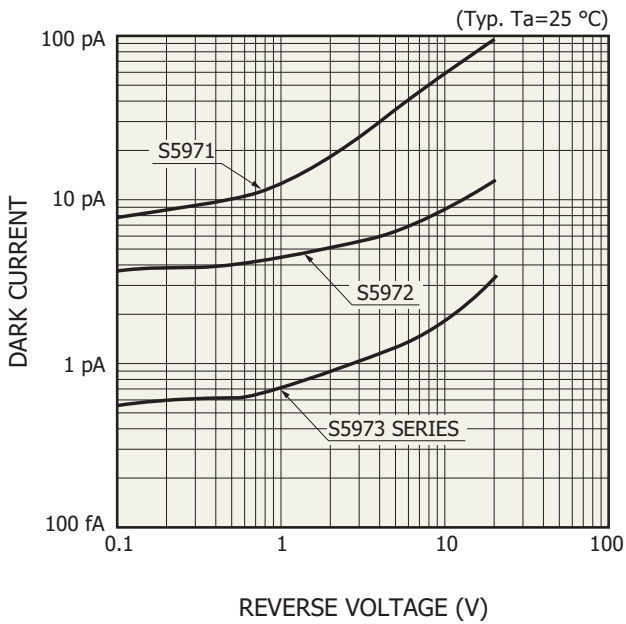

Terminal capacitance vs. reverse voltage

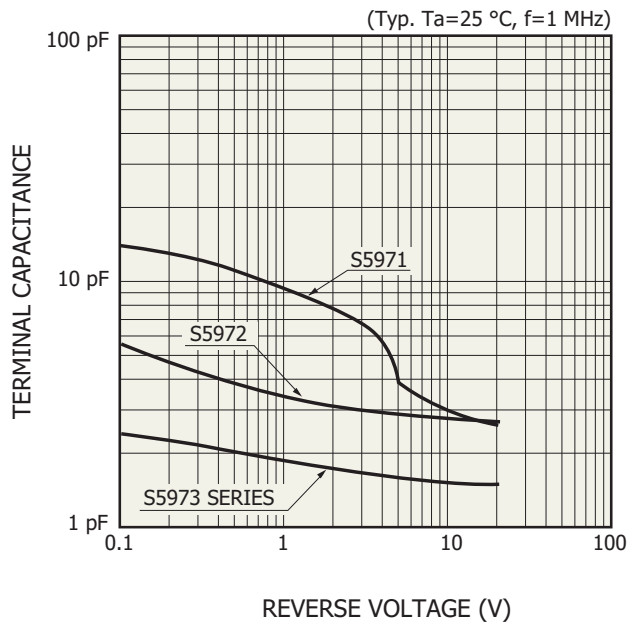

Fiber coupling characteristics (S5973-01)

X, Y direction

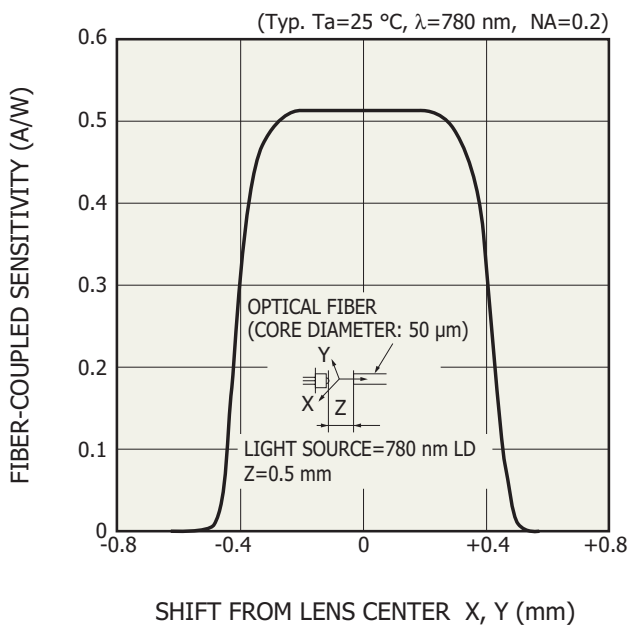

Z direction

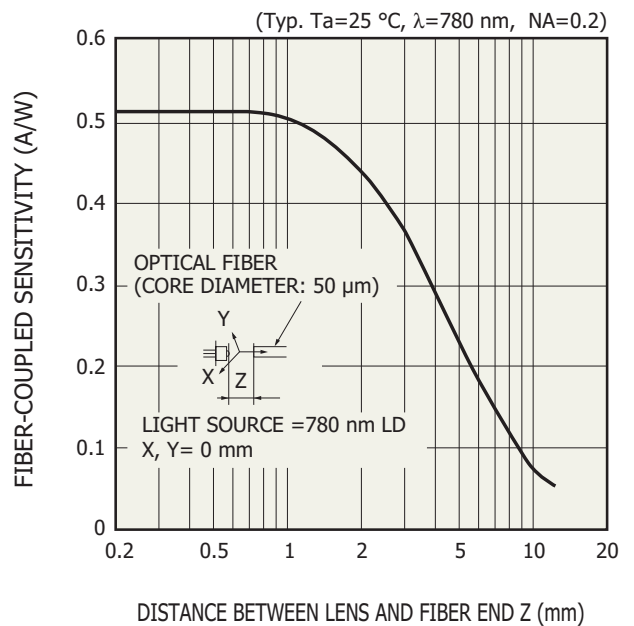

Dimensional outline (unit: mm)

① S5971, S5972, S5973

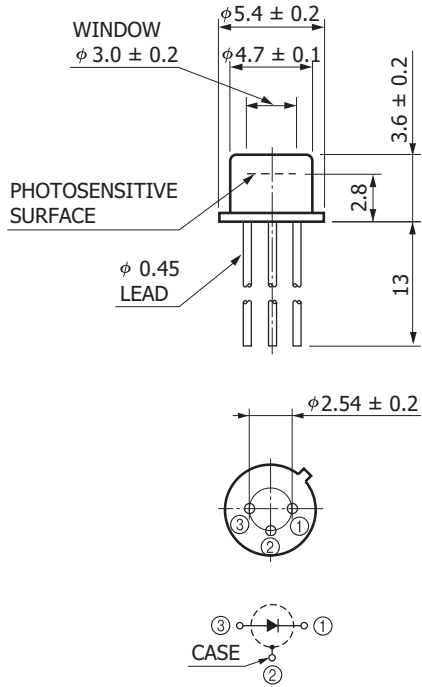

KPINA0022EB

② S5973-01

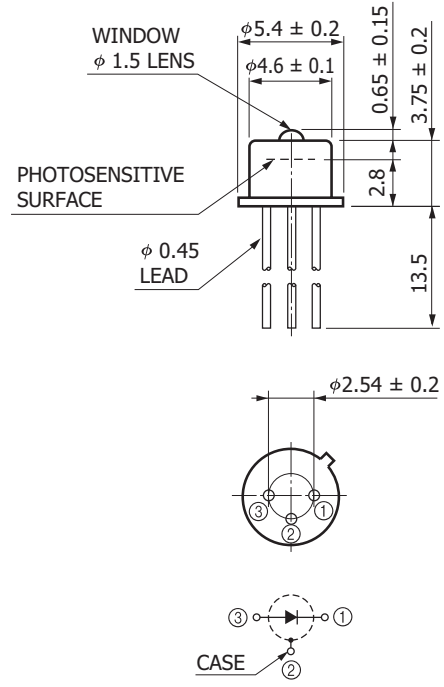

KPINA0023EA

③ S5973-02

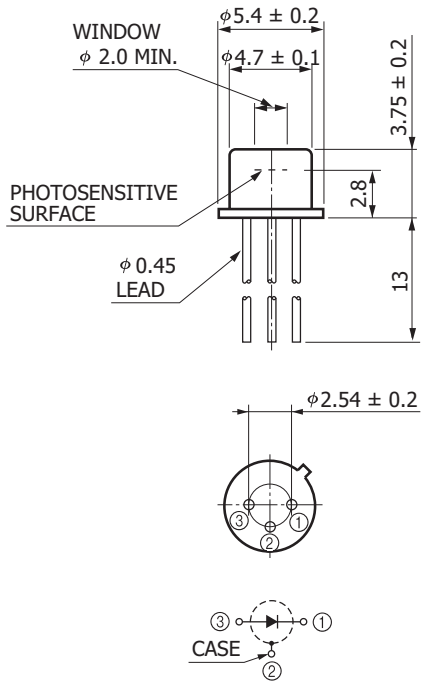

KPINA0061EB

Information described in this material is current as of June, 2011. Product specifications are subject to change without prior notice due to improvements or other reasons. Before assembly into final products, please contact us for the delivery specification sheet to check the latest information.

Type numbers of products listed in the delivery specification sheets or supplied as samples may have a suffix "(X)" which means preliminary specifications or a suffix "(Z)" which means developmental specifications.

The product warranty is valid for one year after delivery and is limited to product repair or replacement for defects discovered and reported to us within that one year period. However, even if within the warranty period we accept absolutely no liability for any loss caused by natural disasters or improper product use.

Copying or reprinting the contents described in this material in whole or in part is prohibited without our prior permission.

HAMAMATSUwww.hamamatsu.com

HAMAMATSU PHOTONICS K.K., Solid State Division

1126-1 Ichino-cho, Higashi-ku, Hamamatsu City, 435-8558 Japan, Telephone: (81) 53-434-3311, Fax: (81) 53-434-5184

U.S.A.: Hamamatsu Corporation: 360 Foothill Road, P.O.Box 6910, Bridgewater, N.J. 08807-0910, U.S.A., Telephone: (1) 908-231-0960, Fax: (1) 908-231-1218

Germany: Hamamatsu Photonics Deutschland GmbH: Arzbergerstr. 10, D-82211 Herrsching am Ammersee, Germany, Telephone: (49) 8152-375-0, Fax: (49) 8152-265-8

France: Hamamatsu Photonics France S.A.R.L.: 19, Rue du Saule Trapu, Parc du Moulin de Massy, 91882 Massy Cedex, France, Telephone: 33-(1) 69 53 71 00, Fax: 33-(1) 69 53 71 10

United Kingdom: Hamamatsu Photonics UK Limited: 2 Howard Court, 10 Tewin Road, Welwyn Garden City, Hertfordshire AL7 1BW, United Kingdom, Telephone: (44) 1707-294888, Fax: (44) 1707-325777

North Europe: Hamamatsu Photonics Norden AB: Smidesvägen 12, SE-171 41 Solna, Sweden, Telephone: (46) 8-509-031-00, Fax: (46) 8-509-031-01

Italy: Hamamatsu Photonics Italia S.R.L.: Strada della Moia, 1 int. 6, 20020 Arese, (Milano), Italy, Telephone: (39) 02-935-81-733, Fax: (39) 02-935-81-741